

564 Diamond-Fyre™ Fireplace



Listed by



AS 4553-2008

GMK10022

IAPMO-R&T OCEANA

- Operation
- Maintenance

WARNING: If the information in these instructions is not followed exactly, a fire or explosion may result causing property damage, personal injury or loss of life.

- Do not store or use gasoline or other flammable vapors and liquids in the vicinity of this or any other appliance.

WHAT TO DO IF YOU SMELL GAS

- Do not try to light any appliance.
- Do not touch any electrical switch; do not use any phone in your building.
- Immediately call gas supplier from a neighbor's phone. Follow the gas supplier's instructions.
- If you cannot reach your gas supplier, call the fire department.
- Installation and service must be performed by a qualified installer, service agency or the gas supplier.

This appliance may be installed as an OEM installation in a manufactured (mobile) home and must be installed in accordance with the manufacturer's instructions and the manufactured home construction and safety standard, Title 24 CFR, Part 3280.

This appliance is only for use with the type(s) of gas indicated on the rating plate. A conversion kit is supplied with the appliance.

Owner's Manual

Dragon Wholesaling Pty. Ltd.

Unit 2, 16 Lexington Drive

Bella Vista NSW 2153

Australia

Introduction

We welcome you as a new owner of a 564 DF gas fireplace. This manual details operation and maintenance of this fireplace. Please familiarize yourself with the Owner's Manual before operating your heater and save the manual for future reference.

Important Information

No other 564 DF gas fireplace has the same serial number as yours. The serial number is on the listing label that is chained to the gas control valve. This serial number may be needed in case you require service.

Model: 564 DF Fireplace

Serial Number: _____

Purchase Date: _____

Purchased From: _____

Register your warranty online at:

traviswarranty.com

Or, mail your warranty card to:

Travis Industries House of Fire
4800 Harbour Pointe Blvd. SW
Mukilteo, WA 98275

Save Your Bill of Sale.

To receive full warranty coverage, you will need to show evidence of the date you purchased your heater. Do not mail your Bill of Sale to us.

We suggest that you attach your Bill of Sale to this page so that you will have all the information you need in one place should the need for service or information occur.

Installation Warnings

- **Installation requirements are printed in the 564 DF Installation Manual (part # 100-01257). All requirements in the installation manual must be met.**
- **Failure to follow all of the requirements may result in property damage, bodily injury, or even death.**
- **This heater must be installed by a qualified installer who has gone through a training program for the installation of direct vent gas appliances.**
- **This appliance must be installed in accordance with all local codes, if any; if not, follow ANSI Z223.1 and NFPA 54(88).**
- **The fireplace is designed to operate on natural gas, or propane (LP).**
- **All exhaust gases must be vented outside the structure of the living-area. Combustion air is drawn from outside the living-area structure.**
- **Notify your insurance company before hooking up this fireplace.**

Table of Contents

Introduction and Important Information

Introduction	2
Important Information	2
Installation Warnings	2
Features	3
Heating Specifications	3

Safety Precautions

Safety Precautions	4
--------------------------	---

Operation

Before You Begin	6
Location of Controls	6
Starting the Fireplace for the First Time	7
Turning the Fireplace On and Off	7
Comfort Control	7
Adjusting the Flame Height	8
Accent Light	8
Adjusting the Blower Speed	9
Continuous Pilot / GreenSmart™ Pilot Switch	9
Normal Operating Sounds	10
Normal Operating Odors	10

Maintenance

Maintaining Your Fireplace's Appearance	11
Battery Replacement	11
Accent Light Replacement	12
Yearly Service Procedure	14
Grill Installation and Removal	15
Face Installation and Removal	16
Glass Frame Removal and Installation	17
Glass Cleaning	19
Troubleshooting Table	20
Wiring Diagram	21
Replacement Part	21

Index

Index	22
-------------	----

Features

- Works During Power Outages (battery backup)
- Standard Blower for Effective Heat Distribution
- Built-In Accent Light (night light)
- Built-In Control Panel Light
- Standing or Intermittent (GreenSmart) Pilot
- Convenient Operating Controls
- Variable-Rate Heat Output
- Low Maintenance

Heating Specifications

	Natural Gas	Propane
Approximate Heating Capacity (in square meter)*	88	88
Maximum Megajoules (MJ) Input Per Hour	21.6	21.6
Minimum Megajoules (MJ) Input on Low	8.5	6.33

* Heating capacity will vary with floor plan, insulation, and outside temperature.

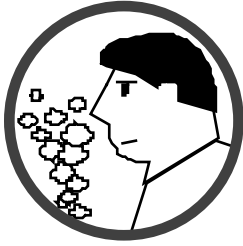
**IF YOU SMELL GAS:**

- * Do not light any appliance
- * Extinguish any open flame
- * Do not touch any electrical switch or plug or unplug anything
- * Open windows and vacate building
- * Call gas supplier from neighbor's house, if not reached, call fire department



This unit must be installed by a qualified installer to prevent the possibility of an explosion. Your dealer will know the requirements in your area and can inform you of those people considered qualified. The room heater should be inspected and cleaned before use and at least annually by a qualified service person. More frequent cleaning may be required due to excessive lint from carpeting, bedding material, etc.

The instructions in this manual must be strictly adhered to. Do not use makeshift methods or compromise in the installation. Improper installation will void the warranty and safety listing.

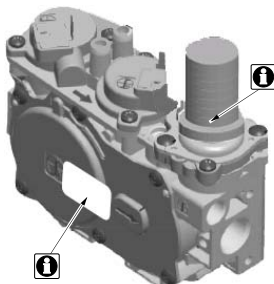

This heater is either approved for natural gas (NG) or for propane (LP). Burning the incorrect fuel will void the warranty and safety listing and may cause an extreme safety hazard. Direct questions about the type of fuel used to your dealer. Check for a label on the flame adjust knob on the gas control valve (this is the best place to check). You may also check for a label on the gas control valve body.



Contact your local building officials to obtain a permit and information on any installation restrictions or inspection requirements in your area. Notify your insurance company of this heater as well.



If the flame becomes sooty, dark orange in color, or extremely tall, do not operate the heater. Call your dealer and arrange for proper servicing.

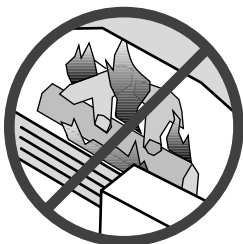

It is imperative that control compartments, screens, or circulating air passageways of the heater be kept clean and free of obstructions. These areas provide the air necessary for safe operation.



Do not operate the heater if it is not operating properly in any fashion or if you are uncertain. Call your dealer for a full explanation of your heater and what to expect.



Do not store or use gasoline or other flammable liquids in the vicinity of this heater.



Do not operate if any portion of the heater was submerged in water or if any corrosion occurs. Immediately call a qualified service technician to inspect the appliance and to replace any part of the control system and any gas control that has been under water.



Do not place clothing or other flammable items on or near the heater. Because this heater can be controlled by a thermostat there is a possibility of the heater turning on and igniting any items placed on or near it.

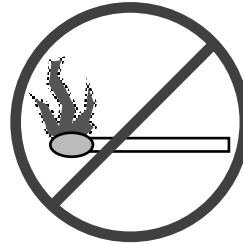

Light the heater using the built-in igniter. Do not use matches or any other external device to light your heater.



The viewing glass should be opened only for conducting service. Do not operate with cracked, broken, or removed glass.

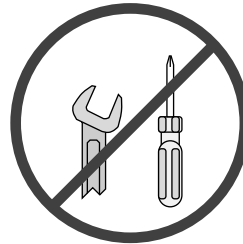

Never remove, replace, modify or substitute any part of the heater unless instructions are given in this manual. All other work must be done by a trained technician. Don't modify or replace orifices.



Operate the heater according to the instructions included in this manual.

If the main burners do not start correctly turn the gas off at the gas control valve and call your dealer for service.

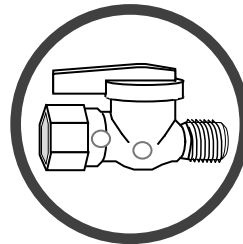

Instruct everyone in the house how to shut gas off to the appliance and at the gas main shutoff valve. The gas main shutoff valve is usually next to the gas meter or propane tank and requires a wrench to shut off.



This unit is not for use with solid fuel

Do not place anything inside the firebox (except listed items).



Do not throw this manual away. This manual has important operating and maintenance instructions that you will need at a later time. Always follow the instructions in this manual.



Children and adults should be alerted to the hazards of high surface temperature and should stay away to avoid burns or clothing ignition. Young children should be supervised when they are in the same room as the heater.



Travis Industries, Inc. grants no warranty, implied or stated, for the installation or maintenance of your heater, and assumes no responsibility of any consequential damage(s).

- Do not place articles on or against this appliance.
- Do not use or store flammable materials near this appliance.
- Do not spray aerosols in the vicinity of this appliance while it is in operation.
- Do not modify this appliance
- Servicing shall be carried out only by authorized personnel.

Before You Begin

- Read this entire manual before you use your new fireplace (especially the section "Safety Precautions" on pages 4 & 5). Failure to follow the instructions may result in property damage, bodily injury, or even death.

Location of Controls

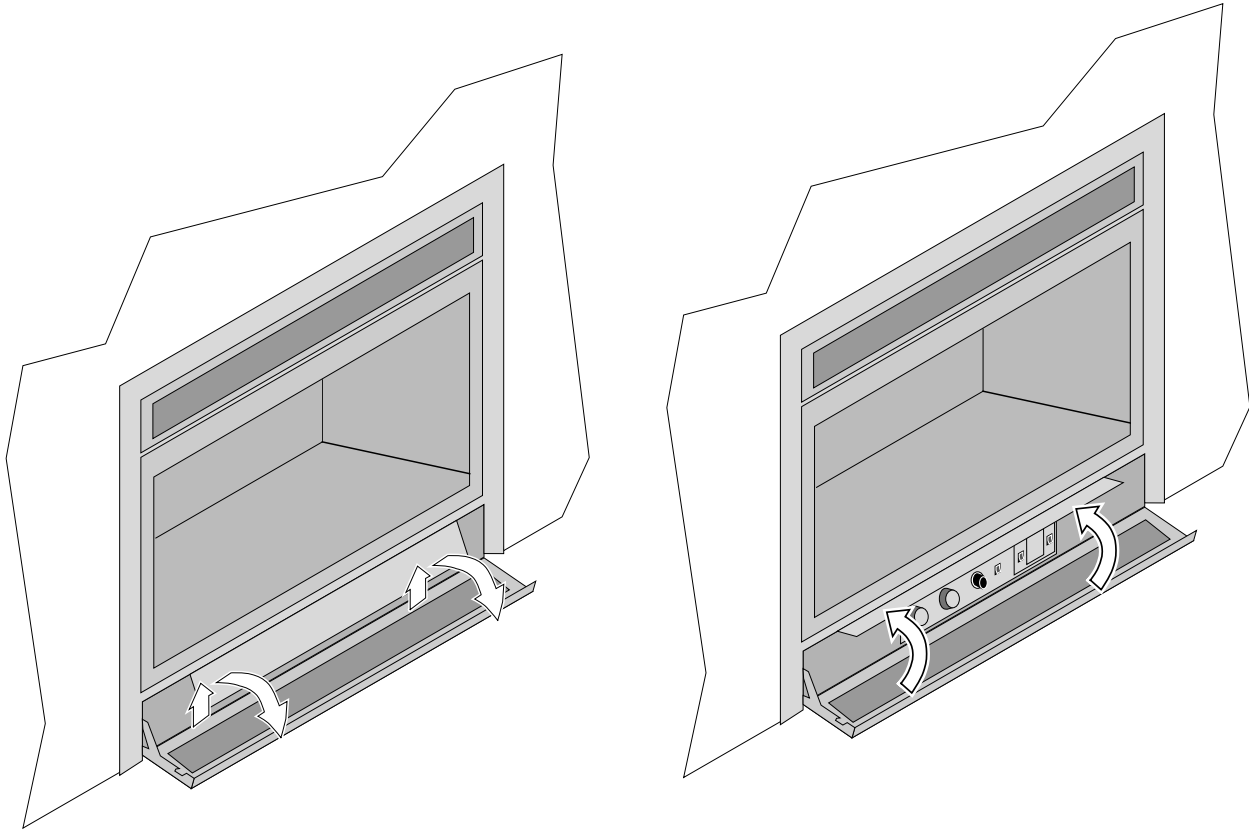

Blower Control	This knob controls the speed of the internal convection blower that pushes heated air into the room.
Accent Light	This knob controls the accent lights.
Flame Adjust Knob	This knob controls the flame height from low ("LO") to high ("HI").
Continuous Pilot -- GreenSmart Pilot	This switch controls how the pilot flame works. See the section "Continuous Pilot / GreenSmart Pilot" for details.
Comfort Control	This switch turns the rear burner on and off.
AA Battery Holder	This holder contains 4 AA batteries that allow the fireplace to operate during power outages.
Main Burner	This switch turns the fireplace burners on and off.

Starting the Fireplace for the First Time

- Burn the heater at a high setting with the blower off for an extended period (up to 48 hours). This will cure the painted surfaces. **Fumes** from the paint curing and oil burning off the steel will occur. This is normal. We recommend opening a window to vent the room.
- **Condensation** may appear on the glass each time you start the fireplace - this is normal.
- **Blue Flames** will occur on the fireplace when it first comes on. After fifteen minutes the flames will turn a more realistic yellow and orange color.
- Certain installations use a remote, thermostat, or wall switch to turn the fireplace on and off. If this is the case, leave the ON/OFF switch "ON".
- Verify the power backup and control light batteries are installed (see page 11).

Turning the Fireplace On and Off

Use the main burner switch to turn the main burner on and off.

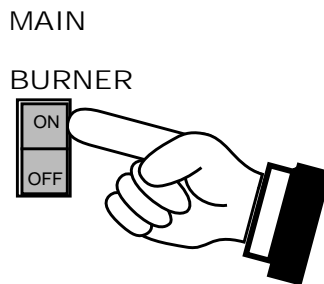

NOTE FOR REMOTES, THERMOSTATS, OR WALL SWITCHES:

The on/off switch on the fireplace may be required to be left in the ON or OFF position for the fireplace to operate. Consult your installer or dealer for details.

- Do not place any combustible items on top of or directly in front of the fireplace, even temporarily. An optional thermostat may start the fireplace causing a combustible item to ignite.
- If the fireplace turns on and off frequently while using the thermostat, you may want to adjust the flame height down until it produces just enough heat needed.

Comfort Control

The sides of the burner may be shut off to lower the heat output and flame size from the burner (this is called the comfort control). Use the comfort control switch to adjust this as desired.

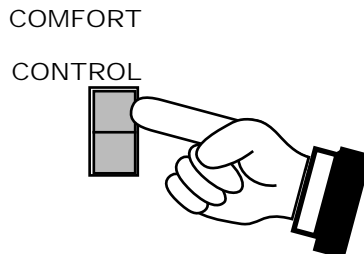

Adjusting the Flame Height

This fireplace has an adjustable flame to tailor the look and heat output to your specific needs. It is adjusted by turning the flame adjust knob.

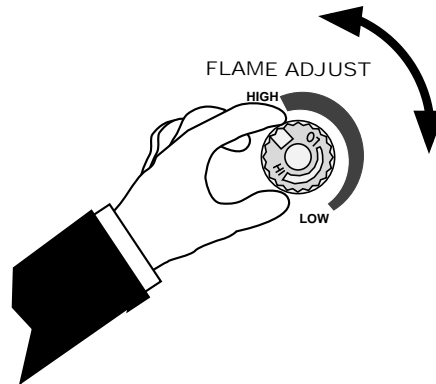

Accent Light

This fireplace has a built-in accent light that may be turned on and off and dimmed to your preference. Turn the knob to achieve the desired light output.

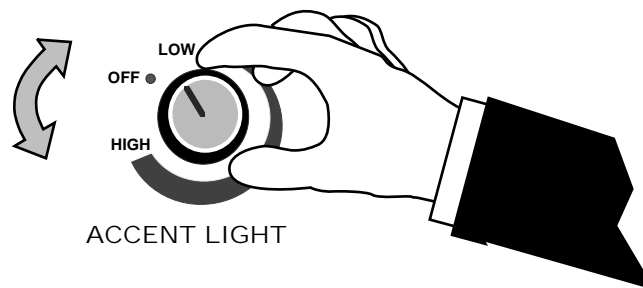

Adjusting the Blower Speed

The blower helps transfer heat from the heater into the room. It will not turn on until the heater is up to temperature (approximately 15 minutes after starting). See the illustration below for instructions on adjusting the blower speed.

NOTE: With the rear burner off (comfort control), the heater may not become hot enough for the blower to turn on.

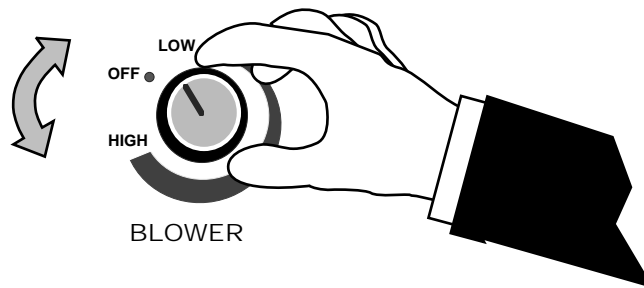

Continuous Pilot / GreenSmart™ Pilot Switch

This fireplace may run with the pilot continuously running or in GreenSmart (intermittent) mode. For most homeowners, the GreenSmart mode is preferred (this saves fuel, doesn't give off un-needed heat). However, in some situations the homeowner may prefer to switch the fireplace to continuous pilot. The most typical reasons for switching to continuous pilot are:

- Very Cold Conditions – in very cold conditions you may notice that the burner does not light quickly, and the flames lift off the burner. If this is situation, we recommend you switch to continuous pilot. This will create a slight draft in the vent, allowing for the burner to light quickly and draft correctly.
- Excessive Condensation on Glass After Startup – certain installations may encounter excessive fogging on the window after startup (not just the first time the fireplace was started). This is an aesthetic condition that may be remedied by switching the fireplace to continuous pilot.
- Cold Glass or Fireplace Front – in very cold conditions you may notice that the fireplace front and glass become very cold. To remedy this, switch the fireplace to continuous pilot.
- Frequent On / Off Operation – if you are frequently turning the fireplace on and off, you may wish to leave it in continuous pilot. This allows the burner to turn on more quickly, without pilot ignition delay.

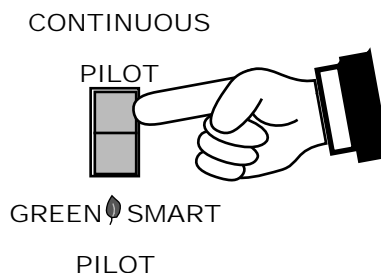

Normal Operating Sounds

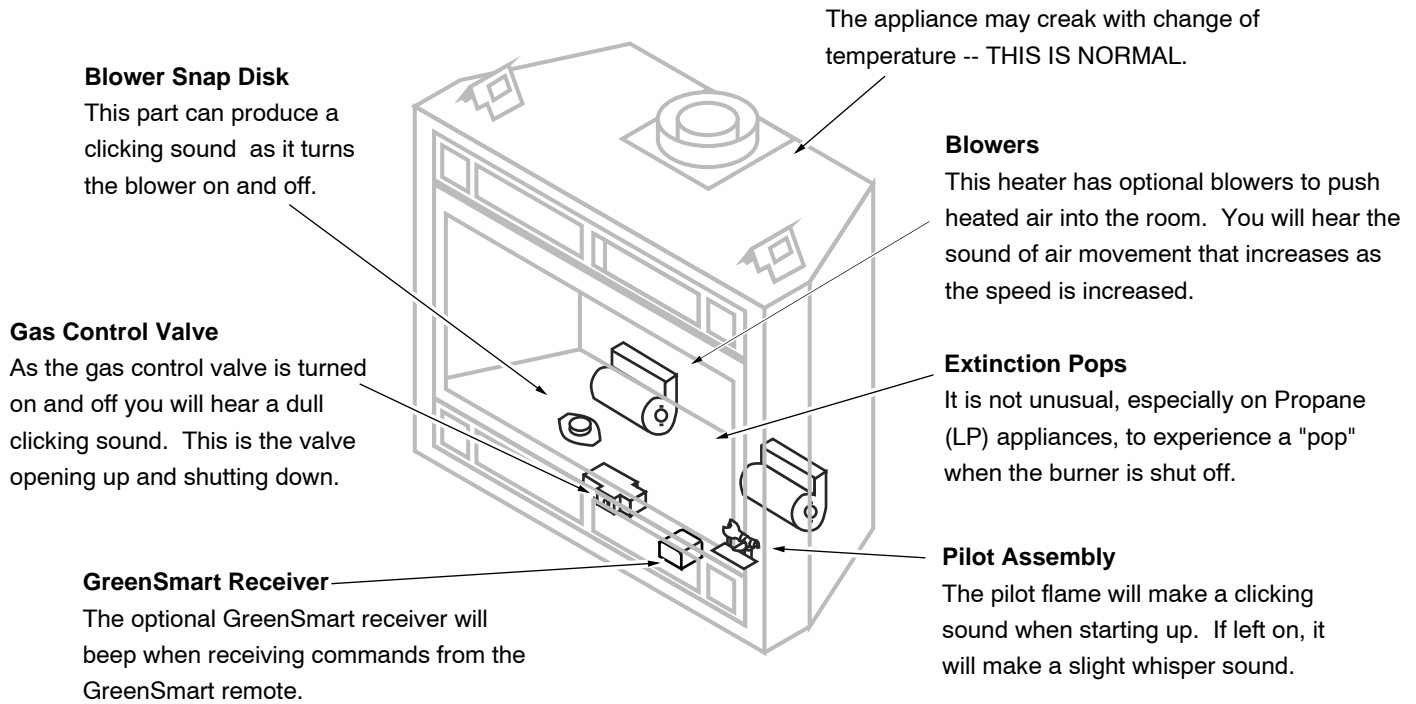

Normal Operating Odors

This appliance has several areas that reach high temperatures. Dust or other particles on these areas may burn and create an odor. This is normal during start-up. You may notice the smell is more acute if the appliance was left idle for a long period.

Maintaining Your Fireplace's Appearance

Fingerprints or other marks left on the optional plated surface may become etched in place if they are not wiped clean prior to turning the fireplace on. Clean the plated surface with denatured alcohol and a soft cloth (with the fireplace cool). Other cleaners may leave a film that may become etched into the surface.

Battery Replacement

Power Backup Batteries

Four AA batteries are used as a power backup for the fireplace in case the household (AC) power goes out. These batteries must be inserted into battery holder (see the illustration below). The fireplace controller will beep once these batteries start to go dead. Replace batteries before each heating season to insure proper operation.

Control Panel Light Battery

LED lights and a 9v battery are used to illuminate the control panel when the concealment cover is lifted. If the LED lights do not operate, replace the 9v battery (see the illustration below). The battery holder is held in place with Velcro and may be removed for easier access.

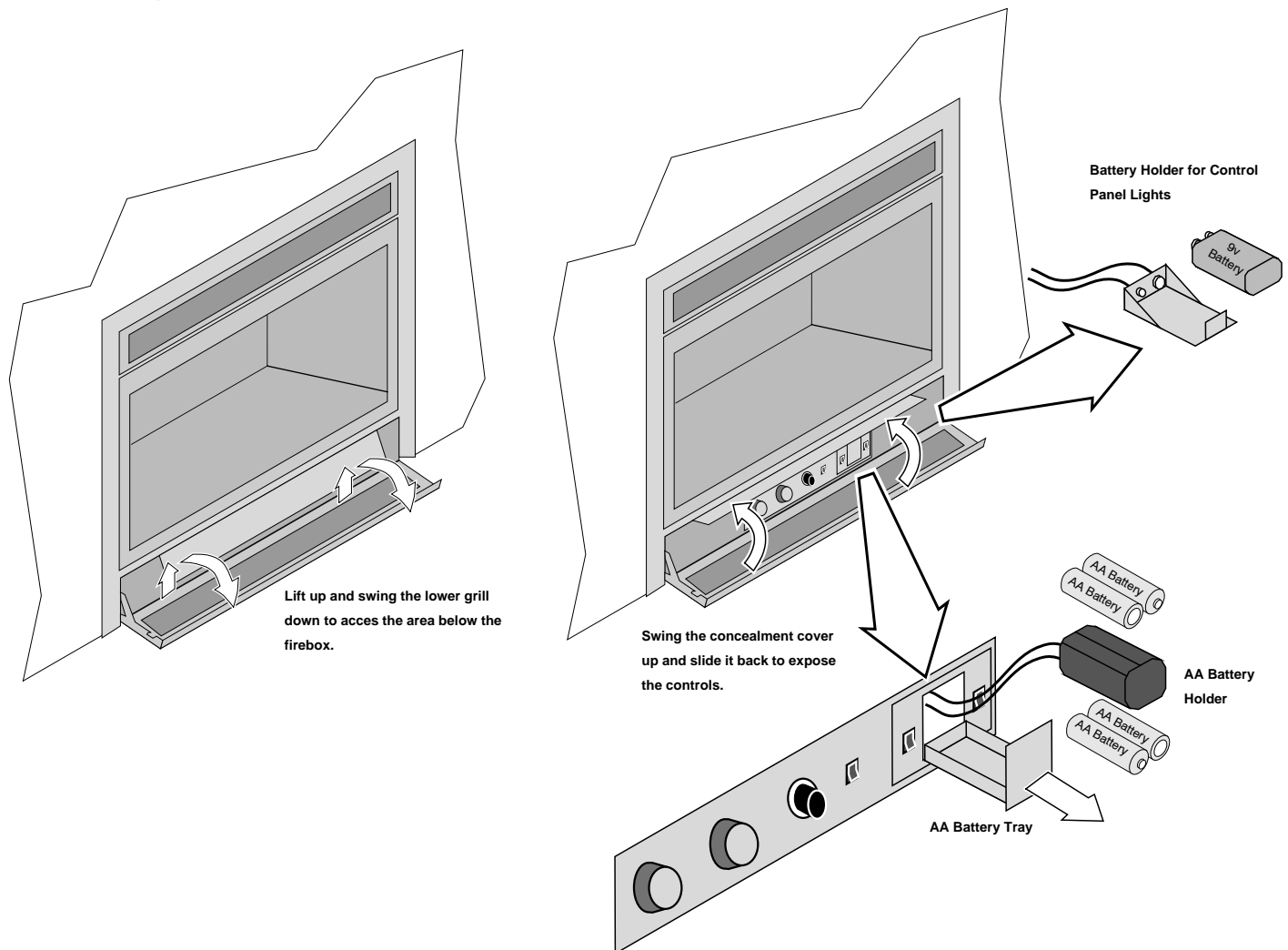

Accent Light Replacement

Six accent lights are included in your fireplace to provide additional lighting. These bulbs will burn out over time. To replace, follow the directions below.

WARNING: Turn off gas and electricity to the fireplace and make sure the fireplace has fully cooled (15 minutes) prior to conducting service.

- 1 Remove the glass frame and place it aside (see page 17).
- 2 Remove the crushed glass. We recommend using a brush and dust-pan to remove the crushed glass from the glass tray (or use a clean shop-vac to remove the crushed glass).

WARNING: The crushed glass may have sharp edges. Handle the glass with leather gloves or use a brush to direct the crushed glass.

- 3 Remove the cast burner cover and place it aside.



NOTE: When replacing the cast burner cover, make sure the notch on the cover fits over the pilot assembly on the right side.



- 4 Remove the four screws securing the glass tray. Lift the tray up and place it aside.



- 5 The six accent lights can be seen in the photo below. When replacing bulbs, you may wish to replace all six simultaneously to minimize service time. Replace the halogen bulbs with the following bulb type:

35 Watt 240 Volt Halogen Bulb for G6.35 Base

NOTE: Take care to not touch the bulb with your fingers – use foam packing or paper towel to hold the bulb

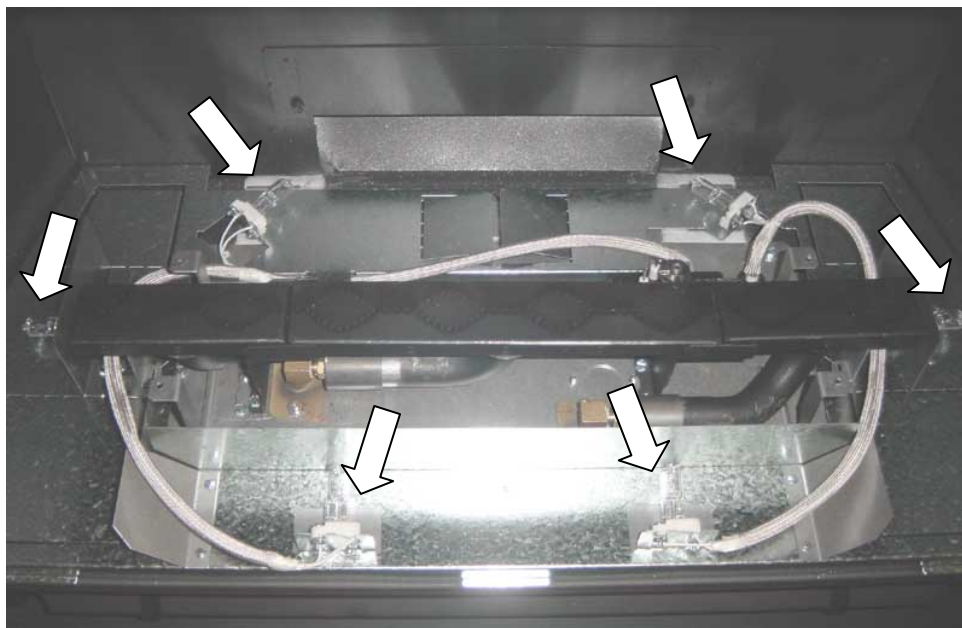

- 6 After replacing the accent light bulbs, restore the fireplace to the original configuration. Make sure the burners are correctly positioned and have not been moved (see photo above for reference). When replacing the crushed glass you may want to use a plastic bag to direct the glass around the perimeter of the burner cover (see photo below). The glass should cover the glass tray and be evenly dispersed.



Yearly Service Procedure

- Failure to inspect and maintain the fireplace may lead to improper combustion and a potentially dangerous situation. We recommend the following procedures be done by a qualified technician.
1. Turn the pilot flame to continuous. It should touch approximately 3/8" of the top of the flame sensor. If it does not, contact your dealer for service.
 2. Shut off gas to the fireplace and let it cool for 15 minutes. Remove the glass (see page 17).
 3. Check for sooting. If excessive sooting is found, the fireplace will require adjustment. Contact your dealer.
 4. Inspect the burner and remove any debris.
 - Make sure the burner is not warped, cracked, or damaged.
 - Check the firebox and area around the pilot to make sure there is no warping or damage.
 - If any problem is found, discontinue use and contact your dealer for service.
 5. Clean and replace the glass (see Glass Cleaning on page 19). If the glass is damaged, replace. Make sure the gasket along the perimeter of the glass contacts the face of the firebox and forms an air-tight seal. If it does not, re-align or replace the gasket to insure an air-tight seal.
 6. Inspect the area behind the access door. Clean if necessary. Check the gas control valve and the gas lines. If damage is found, discontinue use and contact your dealer for service. Clean the air channels, ducts, and blower (if applicable).
 7. Start the main burner. After 15 minutes the flames should be orange/yellow and not touch the top of the firebox. If the pilot or main burners do not burn correctly, contact your dealer for service. Monitor blower operation.
 8. Remove any debris or vegetation near the vent termination. Contact your dealer if any sooting or deterioration is found near the vent termination.

Grill Installation and Removal

Follow the directions below to install.

Upper Grill Installation (FPX and Avalon)

Hold the grill at an angle and insert the lower slot over the lower bushing on the fireplace (both sides)

Swing the grill upwards to engage the upper slot. You will need to lift the grill slightly to get it over the bushing. Once in place the grill is held in place by gravity.

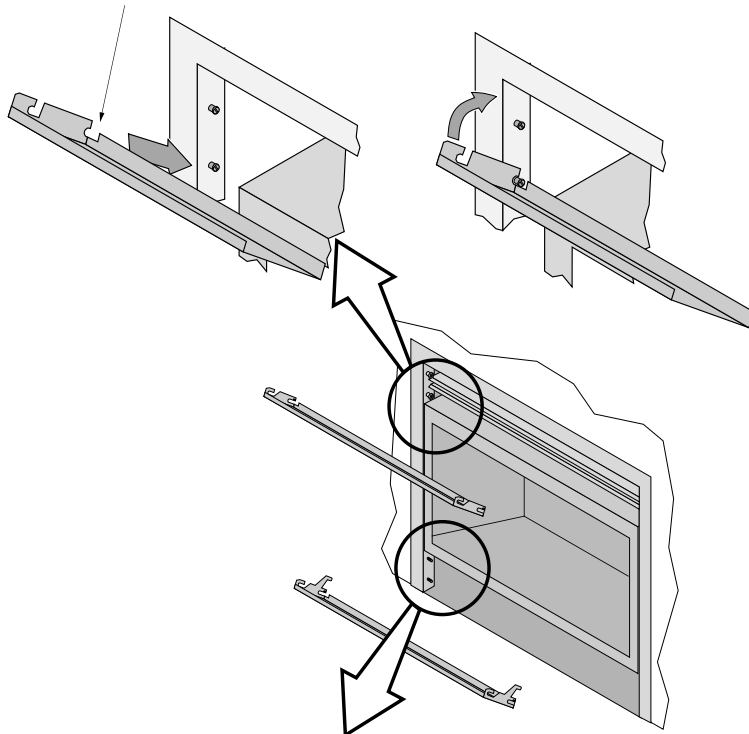

Lower Grill Installation

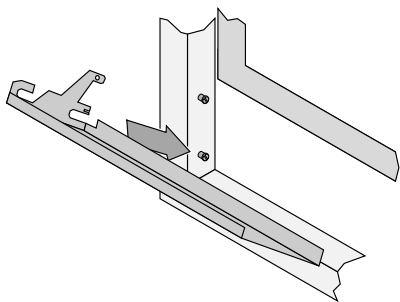

Hold the grill at an angle and insert the lower slot over the bushing on the fireplace (both sides). You may need press on the grill to get the tab over the bushing (this prevents the grill from accidentally falling off).

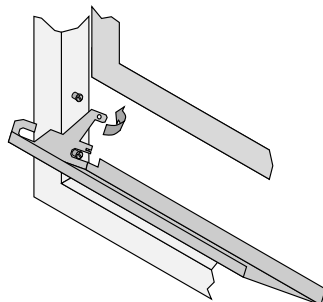

Bend the tab outward on both sides. This is the end-stop for the lower grill, it allows the grill to swing forward.

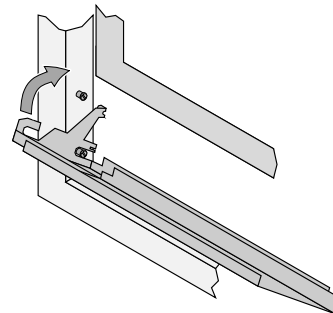

Swing the grill upwards to engage the upper slot. You will need to lift the grill slightly to get it over the bushing. Once in place the grill is held in place by gravity.

Upper Grill Installation (Lopi)

NOTE: The upper grill is difficult to install the first time - be patient, after you install it, you will know how it installs and it will be much easier the second time.

SIDE VIEW

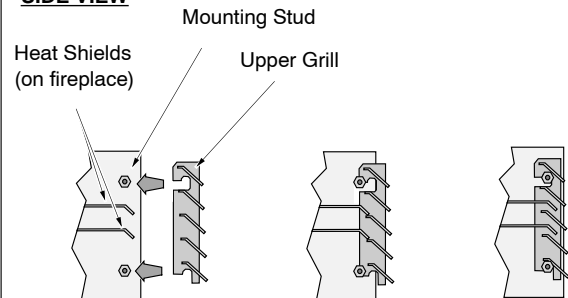

Position the grill so the slots on the grill align with the mounting studs.

You may need to push in and upwards on the grill as it inserts.

The grill, when fully inserted, will slide down and "click" into place.

Face Installation and Removal

Some fireplaces have a face that fits over the glass frame. The face can be removed following the directions below.

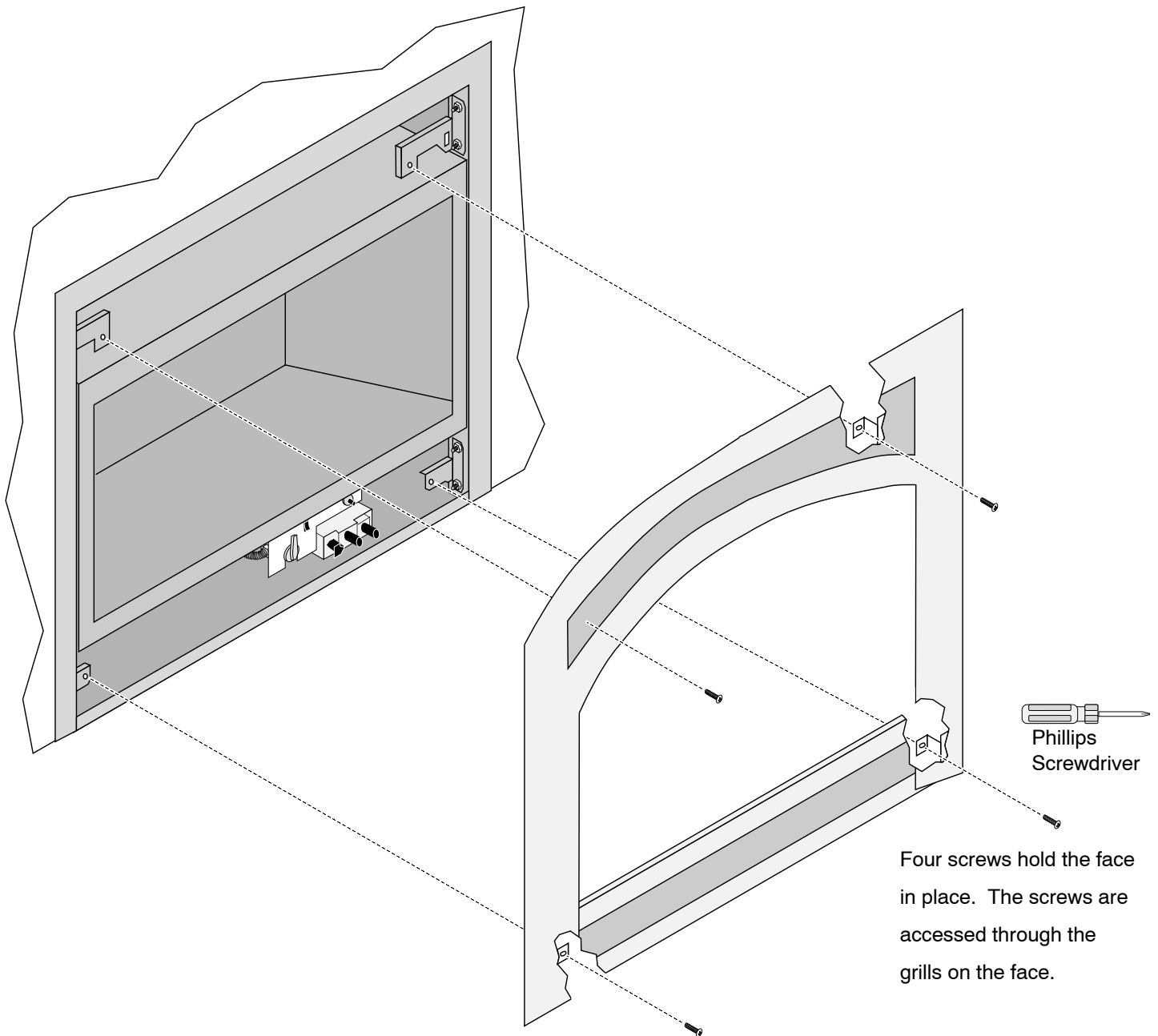

Glass Frame Removal and Installation

Warning: The appliance must be completely cool before removing the glass.

Warning: Do not strike or slam the glass.

- a** Based upon the face being used, either:
 (a) swing the access door down and remove the top grill,
 (b) remove the face (unscrew or lift off - see the instructions included with the face for details).

Open the four latches holding the glass frame in place (start with the bottom) - follow the directions shown to the right.

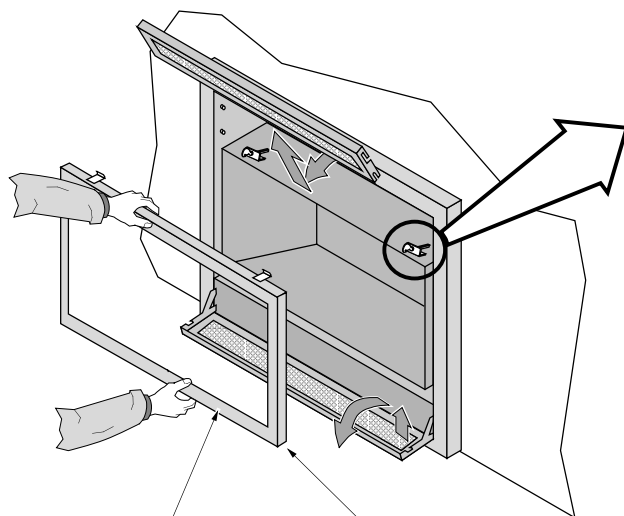

- b** Lift the glass frame up and pull it forward to remove.

NOTE:
 You may need to lift the glass frame while re-attaching.

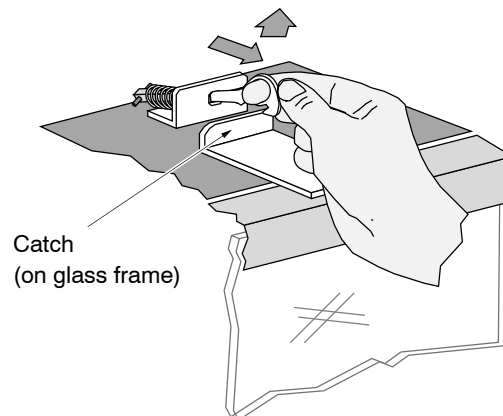
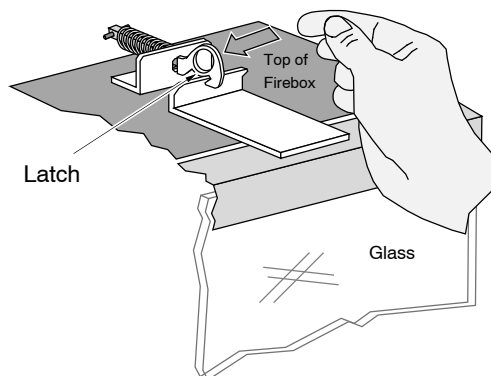

Re-Attaching the Glass Frame:

- a) Hang the glass frame on the firebox.
- b) While holding in place, attach the upper latches (follow the instructions to the right in reverse).
- c) Lift the glass frame slightly and attach the lower latches.

NOTE: Make sure the glass frame is all the way in place - it should be flush with the front of the fireplace when installed.

Glass Frame Removal and Installation (continued)

The latch can come loose from the latch assembly. This occurs only when it is rotated. Follow the directions below to re-install the latch if it comes loose.

Hold the latch at an angle and insert it into the slot on the glass frame anchor.

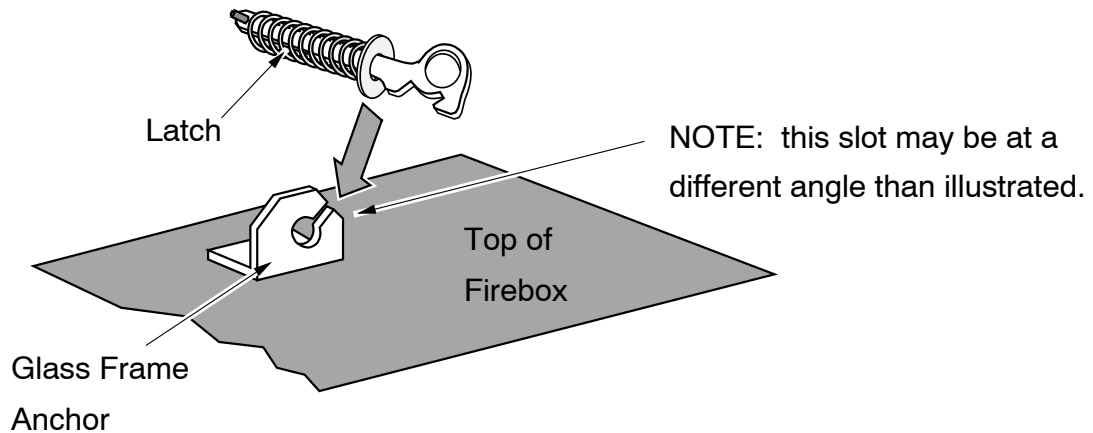

Note how the washer on the latch fits behind the flange on the glass frame anchor.

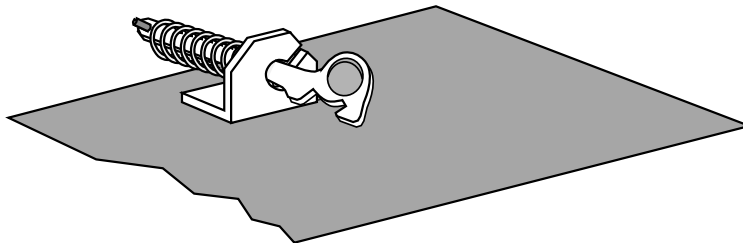

Once fully inserted, turn the latch until it is upright.

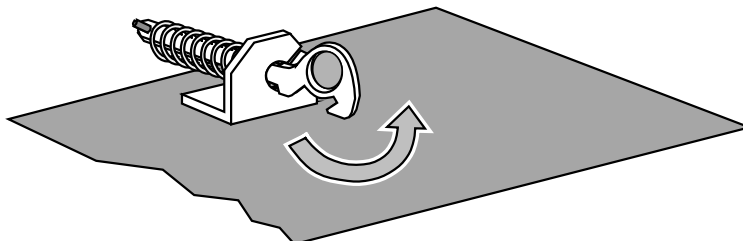

Glass Cleaning

The glass may be cleaned with a non-abrasive cleaner. To clean the inside of the glass, simply remove the glass frame, place it on a non-scratching surface, and clean the inside surface.

If the outside surface of the glass frame requires cleaning, follow the directions below to remove the outer glass frame and screen.

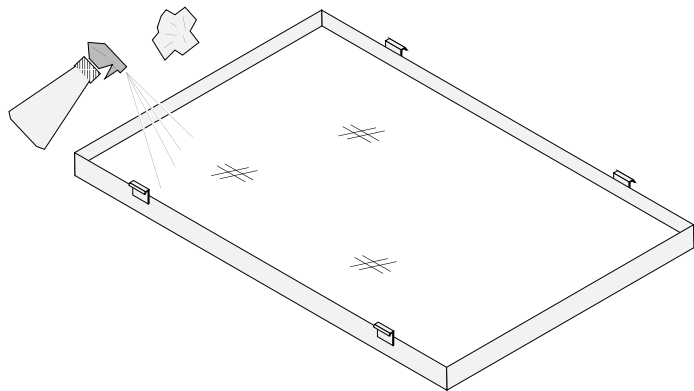

WARNING: do not operate the fireplace without the glass frame in place.

Six sets of tabs hold the glass (and glass gasket) in place. Four of these tabs are at the corners, two are at the top and bottom of the glass frame.

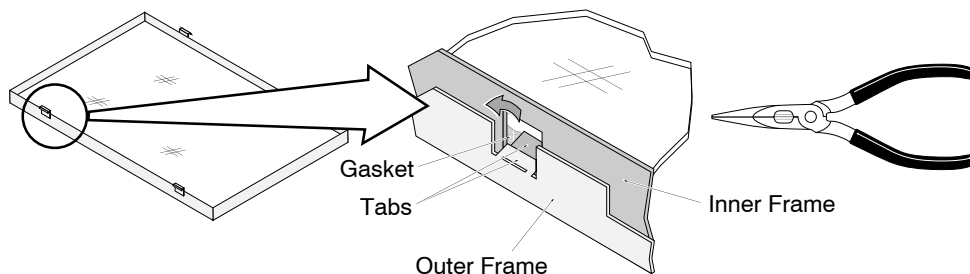

REMOVAL INSTRUCTIONS: carefully bend the tabs out with needle-nose pliers (there are tabs on the inner and outer frame - the center tabs only have tabs on the inner frame). Do not pry these tabs, this may cause the glass to crack.

REPLACEMENT INSTRUCTIONS: carefully bend the tabs inward, making sure the tabs contact the gasket, not the glass. Bend the tab inwards 30° - do not over-bend the tabs.

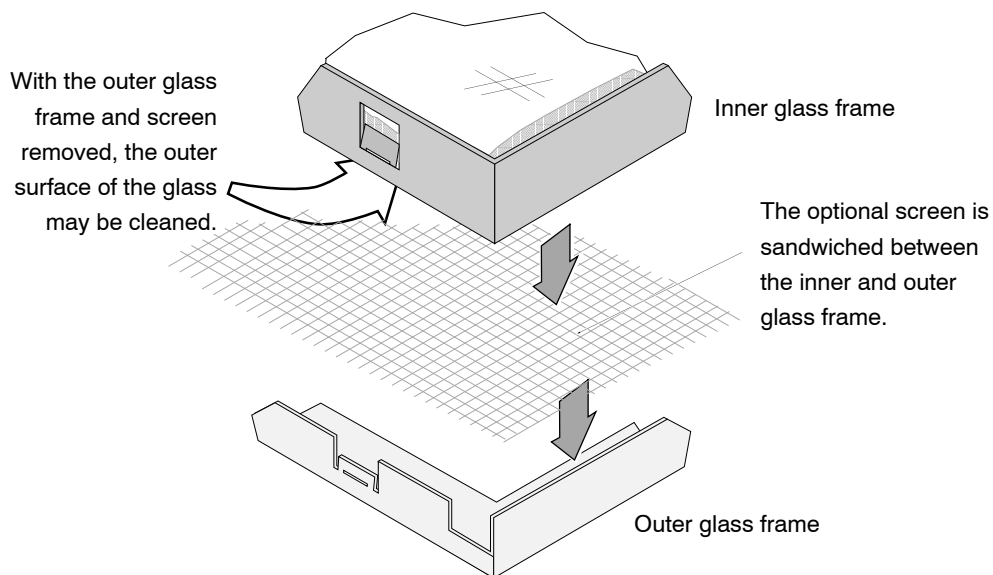

Troubleshooting Table

Problem:	Possible Cause:	Don't Call for Service Until You:
Main Burners Will Not Start	The ON/OFF switch is turned to "OFF" The remote control is not working correctly The thermostat is disconnected or set too low No Propane in Tank	Turn the ON/OFF switch to "ON" See the remote control instructions See "Thermostat Operation" Check Tank Level
Receiver Beeps	The power backup batteries are dead	Replace the batteries (see page 11)
Thermostat Does Not Work	The ON/OFF switch is turned to "OFF" The thermostat is set too low	Turn the ON/OFF switch to "ON" Check thermostat
Fireplace Will Not Distribute Heat	The fireplace is not getting electricity The fireplace is not up to temperature	Check the breaker switch Let the fireplace burn for at least 15 minutes
Flames Are Too Blue	The fireplace has just been started Improper air shutter adjustment	This is normal - see "Starting the Fireplace for the First Time" Adjust Air Shutter - contact your dealer
Flames Are Too Short (Under 6")	The flame height may be turned too low	Turn the flame height to "HI" - See "Adjusting the Flame Height"
Thin Layer of Soot Covers the Glass	Improper air shutter adjustment	Adjust Air Shutter - contact your dealer

Wiring Diagram

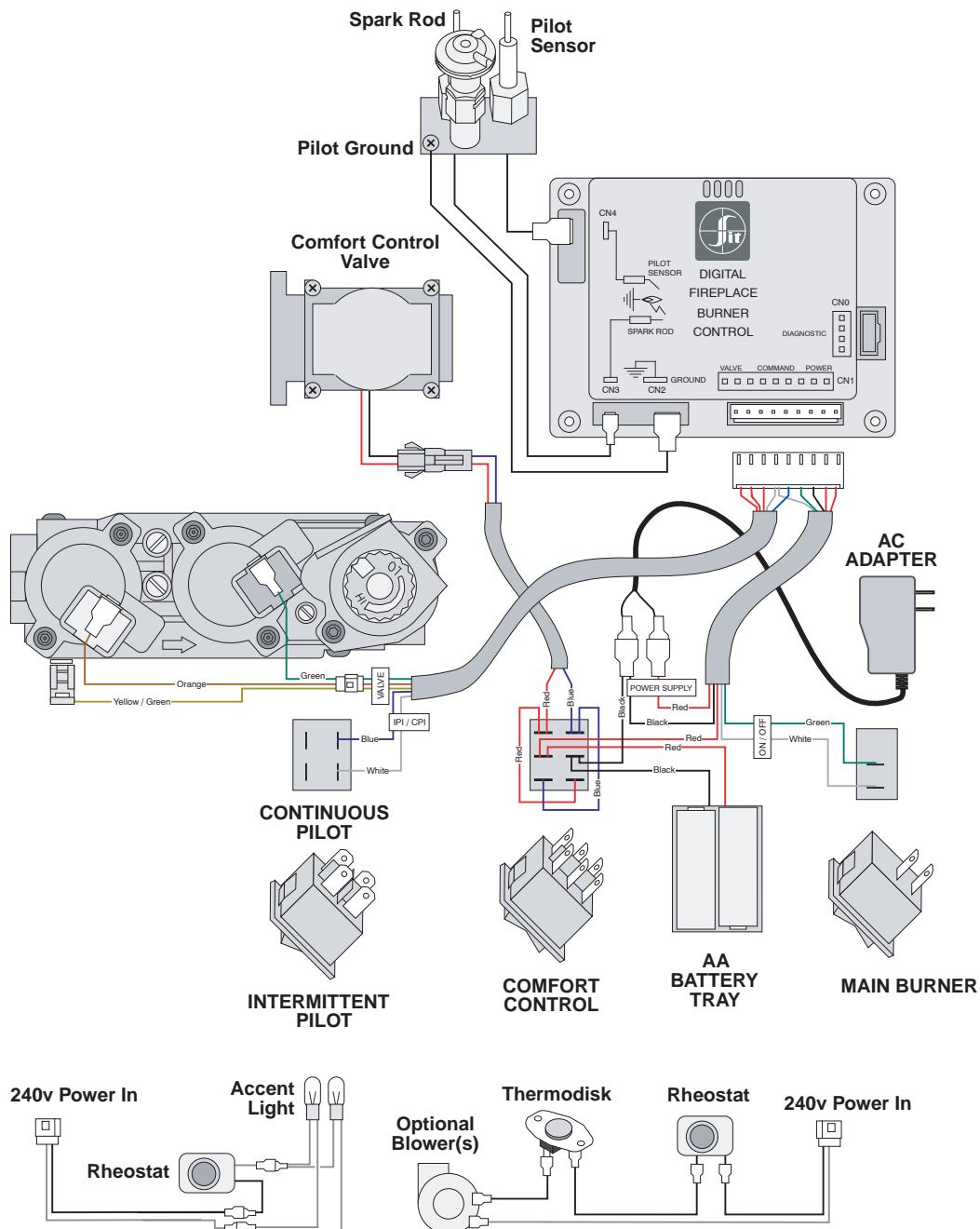

Caution: Label all wires prior to disconnection when servicing controls. Wiring errors can cause improper and dangerous operation.

Replacement Parts

Replacement parts may be ordered through your authorized dealer.

Caution: Use only Travis Industries replacement parts. Do not use substitute materials.

Warning: Do not operate appliance with the glass front removed, cracked, or broken. Replacement of the glass should be done by a licensed or qualified service person.

Index

Accent Light Replacement	12
Accent Light	8
Adjusting the Flame Height	8
Adjusting the Blower Speed	9
Battery Replacement	11
Before You Begin	6
Comfort Control	7
Continuous Pilot / GreenSmart™ Pilot Switch	9
Face Installation and Removal	16
Features	3
Glass Cleaning	19
Glass Frame Removal and Installation	17
Grill Installation and Removal	15
Heating Specifications	3
Important Information	2
Index	22
Installation Warnings	2
Introduction	2
Location of Controls	6
Maintaining Your Fireplace's Appearance	11
Normal Operating Odors	10
Normal Operating Sounds	10
Safety Precautions	4
Starting the Fireplace for the First Time	7
Troubleshooting Table	20
Turning the Fireplace On and Off	7
Wiring Diagram	21
Yearly Service Procedure	14